

Motion to meet the highest demands



Electromechanics made by Parker
Product overview



Product overview Electromechanics



■ Visualisation __4

- Systems for Control & Monitoring
- Touch Screens
- Software for Windows®-based HMI



■ Motion control __5

- Controllers for high-technology applications
- PLC based Motion Control Systems
- Digital and analogue peripheral modules



■ Drive technology __7

- AC servo drives for centralised and decentralised automation
- DC servo drives
- Stepper motor drives

Interfaces for automation:

- +/-10V or Step/Direction
- Digital Inputs & Outputs
- RS232 / RS485
- Profibus
- CANopen
- SERCOS
- DeviceNet
- PowerLink

Feedback systems:

- Tacho generator
- Resolver
- Encoder
- Sinus/Cosinus
- SinCos® Hiperface
- EnDat®
- Analogue Hall
- Distance coded

Click here!

Click here for more detailed information on our website.

- Servo motors
- Stepper motors
- Linear servo motor kits
- Torque motor kits

- Economy
- Precision

■ Motors __9

■ Planetary gearboxes __11



■ Handling actuators __12

■ Precision actuators & tables __14

- Linear actuators
- Vertical actuators
- Electric cylinder
- Linear motor actuators (PowerRod)

- Linear actuators
- Tables (X-Y and rotary)
- Miniature tables
- Stacking tables



■ Control & Monitoring (Visualisation)

Parker's components for control, monitoring and user interfacing are suitable for a wide range of applications. They range from simple, cost-efficient two-line displays to colour touch screens. Modern, Windows® based software tools support the user in application programming as well as integration of the components into machine and company networks.

Pop series

Pop technical data (summary)

	Pop 11	Pop 12	Pop 21	Pop 22	Pop 23	Pop 31	Pop 32
Display	mono text	mono graphic	mono graphic	mono graphic	mono graphic	mono 5.6" diagonal	colour 5.6" diagonal
Size	2 lines 20 characters	4 lines 20 characters	4 lines 20 characters	4 lines 20 characters	8 lines 40 characters	16 lines 40 characters	16 lines 40 characters
Function keys	4	4	12	12	23	Touch	Touch
LED	5	5	13	13	24	-	-
Multi-lingual projects	✓	✓	✓	✓	✓	✓	✓
Fieldbus option	✓	✓	✓	✓	✓	✓	✓
RS232, RS422	✓	✓	✓	✓	✓	✓	✓
RS485, CL 20mA	✓	✓	✓	✓	✓	✓	✓
Printer interface	-	-	-	-	✓	✓	✓
User program	512 kB	512 kB	512 kB	512 kB	512 kB	8 MB	8 MB
Memory expansion	-	-	512 kB	512 kB	512 kB	-	-
Recipe memory	-	-	-	32 kB	16 kB	32 kB	32 kB
Downloadable font	-	✓	✓	✓	✓	-	-
Numeric keypad	-	-	✓	✓	✓	Touch	Touch
Real time clock, battery	-	-	-	✓	✓	✓	✓
Event list for alarms	-	-	-	✓	✓	✓	✓
Screen saver	-	-	-	-	-	✓	✓

Note: Device drivers are available for a range of PLC systems



Pop 12



Pop 22



Pop 23



Pop 32

Interact/InteractX™ series

The Interact/InteractX™ software package was developed for the visualisation (control & monitoring) of complete machines and process plants. Interact features a very simple interface and extensive graphics elements. The package includes a number of software modules for recipe management, trend analysis etc. We offer an extensive package of drivers for almost all PLC systems. Interact was especially designed for cost-efficient, embedded hardware platforms.

Parker offers touch screens in 6", 10", 12" and 15" sizes.

Software functions include:

- Exceptionally realistic 3D graphic elements (Panel Tools)
- Freely configurable graphic elements
- Alarm functions
- OPC Client/OPC Server
- Active-X™ support
- Visual Basic® for application software
- Multi-lingual projects
- Communication interfaces for system integration
- Compatible with the 21CFR11 standard

■ Motion controls

Parker Hannifin offers advanced and extremely powerful platforms for the control of complex, multi-axis motion sequences.

ACR Controllers

ACR controllers are powerful motion controllers designed to perform complex tasks. The controllers can perform multiple tasks simultaneously, and typically up to 24 programs can be processed in parallel. The product incorporates powerful functions such as batch compensation, electronic cam generation, fast trigger inputs, 3D-contour movements and tangential axes. In addition, Visual Basic® and C++ libraries are available for the user.



ACR9000

ACR controller technical data (summary)

	ACR9000
Number of axes (Servo, Stepper)	1 to 8
CPU Performance	150MFLOPS
Digital I/Os	24/48 can be extended to 1024 via CANopen and PIO
I/O voltage	24 V

C3 powerPLmC

C3 powerPLmC is a new automation platform for combined PLC, Motion Control and visualisation tasks. The C3 powerPLmC control system is based on internationally recognised standards in programming, communication and interfacing. Programming follows the IEC61131-3 standard, and the powerful platform executes 1000 IL instructions in less than 100µs. This makes the C3 powerPLmC one of the fastest and most powerful PLCs for motion control tasks.

The standard Ethernet interface included with the package forms the basis for the state-of-the-art remote diagnostics via the Internet or Intranet. Parker has integrated an OPC Interface into the control system for connecting open Windows-based process visualisation and supervisory systems.

The Drive Interface guarantees the simple integration of Parker Hannifin's Compax3 Servo Controllers into Machines Automation Structures without detailed knowledge about Field Bus Systems.

Your advantage: Time- and cost-saving.

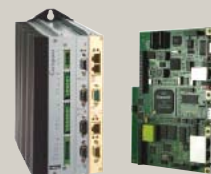

Compax3 powerPLmC-C1x



C3 powerPLmC-E2x

C3 powerPLmC technical data (summary)

		Compax3 powerPLmC-C1x (with integrated axis)	C3 powerPLmC-E2x (standalone)
General information	Platform	32 Bit RISC, 200 MHz	32 Bit RISC, 200 MHz
	Boot Flash/Program memory FLASH	1 Mbyte/4 Mbyte	64 MB Compact Flash
	Data memory SDRAM/Data memory non volatile	16 Mbyte/32 kByte NVRAM	16 Mbyte/32 kByte NVRAM
	Real time clock	Yes, battery backed	Yes, battery backed
	Operating system/supply	Real-time multitasking / 24 V DC	Real-time multitasking / 24 V DC
	Servo extention	Compax3 - axis	-
Controller features	Processing time	< 100 µs/1000 IL lines	< 100 µs/1000 IL lines
Programming/Debugging	Programming system	CoDeSys	CoDeSys
	Programming languages	IL, KOP, FUP, ST, AS, CFC	IL, KOP, FUP, ST, AS, CFC
Protocol		IEC61131-3, PLCopen	IEC61131-3, PLCopen
	Program interface	Fast Ethernet	Fast Ethernet
Visualisation	Local/OPC Server	yes/yes	yes/yes
Interfaces	Fieldbusses (standard)	CANopen, Ethernet 10/100	2*CANopen, Ethernet 10/100
	Fieldbusses (option)	Profibus DP Slave	Profibus DP Slave
	Serial interfaces	-	2*RS232/2*RS232/RS422/RS485
	Digital I/Os	PIO External terminals	PIO External terminals

Peripheral modules – PIO digital and analogue inputs/outputs

Parker Hannifin's PIO modular bus terminal system uses the associated sensors to record a wide variety of control signals from field devices. Connections to the field level can be implemented quickly and reliably with PIO.

- **Fieldbus-independent design using fieldbus couplers**
 - Profibus
 - CANopen
 - DeviceNet
- Easy to extend by replacing modules
- Exceptionally compact design
- Intrinsically-safe contacting
- Different voltages can be combined



PIO-400



PIO-430



PIO-468



PIO-550

PIO technical data (summary)

	Digital Inputs	Analogue Inputs	Digital Outputs	Analogue Outputs
	PIO-400	PIO-456	PIO-501	PIO-550
	PIO-402	PIO-468	PIO-504	PIO-552
	PIO-430	PIO-480	PIO-530	PIO-556
Number of I/Os	2/4/8	4/2	2/4/8	2/2
Data width	2/4/8 Bit	4*2/2*2 Byte	-	-
Connection	2 - 4 wire 2 - 3 wire single wire positive switching	single ended differential input 12/14 Bit +/-10V	short-circuit proof positive switching	short-circuit proof positive switching 12 Bit +/-10V
Signal	DC-3V to +5V DC 15V to 30V	0V to 10V 0mA to 20mA	0.5 A	0V to 10V 0mA to 20mA
Dimensions	12 x 64 x 100	12 x 64 x 100	12 x 64 x 100	12 x 64 x 100

■ Drive technology

Parker Hannifin's drives are based on integrated digital technology. This is a prerequisite for higher power density of the stepper and servo motor drives. The outstanding features of small dimensions, high functionality and standardised interfaces simplify the integration into machines and process plant.

Drive systems for high-technology applications

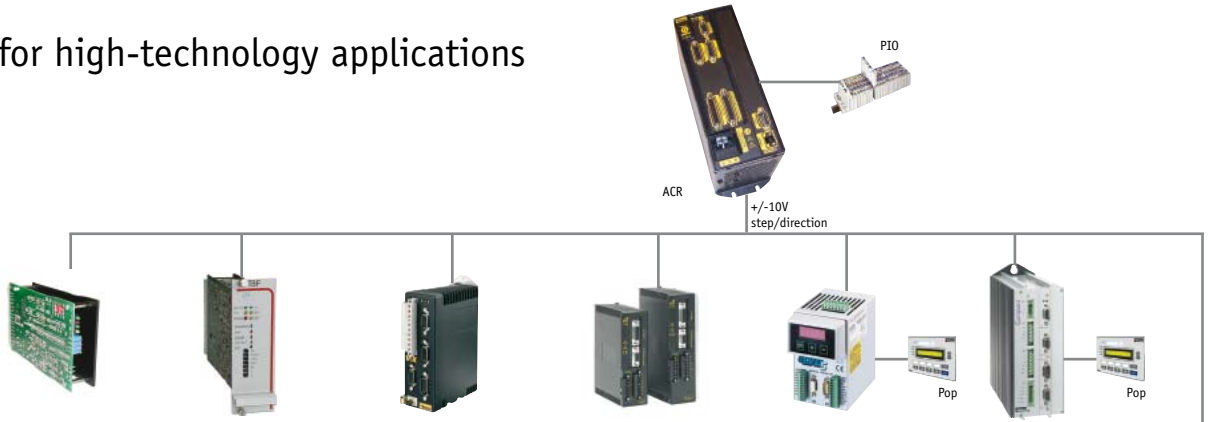

Centralised controller structure

Servo drive data

	TRM	TBF/TBL	ViX Servo	Aries	sLVD	Compax3 I10T10
Supply voltage	24/54VAC or 34/76VDC	60/120/250VAC	24 – 80VDC	120/240VAC	240VAC	240/480VAC
Phases		1	DC Bus	1	3	1/3
Output current ratings (continous/peak)	7/15A (24VAC) 5/15A (54VAC) 8/20A (54VAC)	5/10A (60VAC) 10/25A (60VAC) 7/18A (120VAC) 2.5/5A (120VAC) 10/20A (120VAC) 15/30A (120VAC) 10/20A (250VAC)	2.5/7.5A 5.0/15A	1.0/3.0A 1.75/5.25A 3.0/9.0A 4.5/13.5A 6.3/14.2A	1.25/2.5A 2.5/5.0A 5.0/10.0A 7.0/14.0A	2.5/5.0A (1AC230V) 6.3/12.6A (1AC230V) 10/20A (3AC230V) 15/30A (3AC230V) 1.5/4.5A (3AC400V) 3.8/9.0A (3AC400V) 7.5/15.0A (3AC400V) 15.0/30.0A (3AC400V) 30.0/60.0A (3AC400V)
Feedback	Tacho generator	Resolver Encoder	Encoder Resolver SinCos®	Encoder	Resolver	Resolver/Encoder, Sine/Cosine, SinCos®, EnDat®, Analogue Hall, Distance coded
Command interface	+/-10V	+/-10V	+/-10V 5 V S/R	+/-10V 5 V S/R	+/-10V 5 V S/R	+/-10V 5 V S/R; 24 V S/R
Integrated digital I/O	-	-	5/3	-	3/2	4/4
Integrated analogue I/O	-	-	-	-	-	2/2
System structure	centralised	centralised	centralised decentralised	centralised	centralised decentralised	centralised decentralised
Special features	DC – servo controllers in 19" Rack	19" Rack suitable for external Commutation				Safety technology on board (safe standstill according to EN954-1)

The servo drives for high-technology applications are complemented by powerful stepper motor drives.

Stepper motor drives technical data (summary)

	XL	ViX Stepper
Supply voltage	24/48/80VDC	24/48/80VDC
AC phases or DC bus	DC Bus	DC Bus
Rated output current (continuous)	1.8A RMS 3.5A RMS 5.6A RMS	2.8A RMS 5.6A RMS
Command interface	S/R Differential TTL	S/R Differential TTL
System structure	centralised decentralised	centralised decentralised
Special features	Ministep power step	Ministep power step

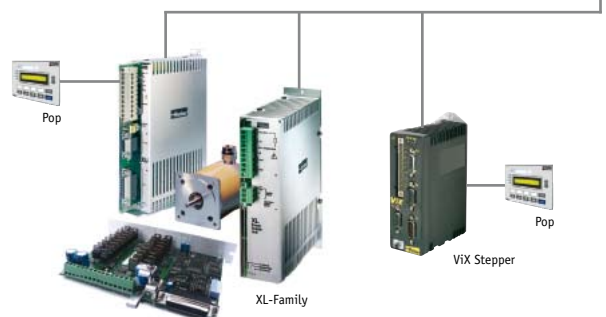

Drive technology for PLC controlled applications

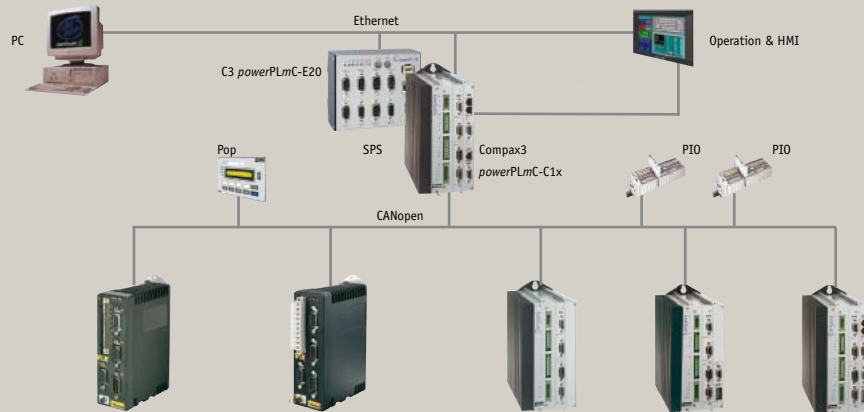

Decentralized controllers structure

	ViX Stepper	ViX Servo	Compax3 T11, Compax3 T30, Compax3 T40
Supply voltage	24 ... 80VDC	24 ... 80VDC	240/480VAC
Phases	DC Bus	DC Bus	1/3
Output current ratings (continuous/peak)	2.8; 5.6	2.5/7.5A; 5/15A	(1AC230V): 2.5/5.0A; 6.3/12.6A (3AC230V): 10/20A; 15/30A (3AC400V): 1.5/4.5A; 3.8/9.0A; 7.5/15.0A; 15.0/30.0A; 30.0/60.0A
Feedback	Encoder	Encoder, Resolver, SinCos®	Resolver, Encoder, Sine/Cosine, SinCos®, EnDat®, Analogue Hall, distance-coded
Command interface	5 V S/R	+/-10V, 5 V S/R	Encoder, Fieldbusses, digital I/O, Real-time bus
Fieldbus (option)	CANopen	CANopen	CANopen, Profibus DP, DeviceNet, PowerLink
Decentralised technology functions	Mark synchronisation	Mark synchronisation	Mark synchronisation, electronic gearbox, electronic cam generation (Compax3 T40)
Decentralised programming	EASI-Code	EASI-Code	Positioning sets (Compax3 T11), IEC61131-3, PLCopen (Compax3 T30, T40)
Integrated digital I/Os	5/3	5/3	8/4 + 12
Integrated analogue I/O	-	-	2/2
System structure	Centralised, decentralised	Centralised, decentralised	Centralised, decentralised
Special features	Microstep motor drive		Safety technology on board (safe standstill according to EN954-1)

Drive technology for CNC controlled applications

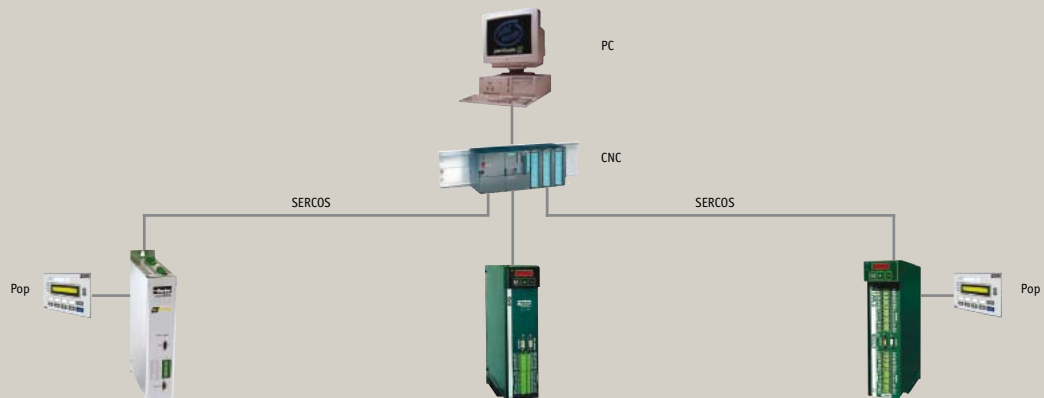

Technical data (summary)

	HiDrive	SPD	TWIN/SPD
Supply voltage	230 ... 480VAC	380 ... 480VAC	380 ... 480VAC
Phases	3	3	3
Output current ratings	2/4A; 5/10A; 8/16A; 16/32A; 25/50A; 50/100A; 100/200A	2/4A; 5/10A; 8/16A; 16/32A; 25/50A	2/4A; 5/10A; 8/16A; 16/32A; 25/50A
Feedback	Resolver, SinCos, Sincos & EnDat (single & multiturn) Encoder*		
Command interface / fieldbus	SERCOS		
Decentralised technology functions	Electronic gearbox, electronic cam		
Decentralised programming	Pico PLC (simple movements)	Pico PLC (simple movements)	Pico PLC (simple movements)
Integrated digital I/O	4/2	4/2	4/2
Integrated analogue I/O	2/2	2/1	2/1
System structure	centralised, decentralised	centralised, decentralised	centralised, decentralised
Special features			2 independent drive controllers (SPD) in one housing

*not all possible configurations are supported

■ Motors

Servo motors

Servo motors developed and manufactured by Parker Hannifin, offer an ideal solution for many applications.

They are suitable for both highly-dynamic machines and applications requiring accurate synchronization. All motors are designed using high-quality neodymium-iron-boron magnets. Special flanges and options offer increased flexibility, and all motors are designed with IP64 protection. These motors are notable for exceptional flexibility and wide power range.

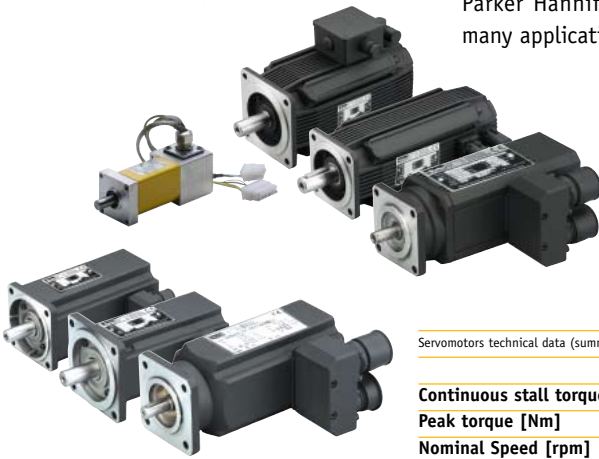

Servomotors technical data (summary)

	SMH/SMB/SME	MH/MB/ME
Continuous stall torque [Nm]	0.2-19	0.2-126
Peak torque [Nm]	1.3-47	1.3-398
Nominal Speed [rpm]	1800-7500	550-10000
Rotor inertia/ Rotor [kgmm²]	4-1400	11-14000
Flange sizes (selection)	40x40 / 60x60 / 82x82 / 100x100 / 115x115 / 142x142	56x56 / 70x70 / 105x105 145x145 / 205x205
Feedback	Resolver / Incr. Encoder / Absol. Encoder/SinCos®, EnDat®	Resolver / Incr. Encoder / Absol. Encoder/SinCos®, EnDat®
Servo controller	SMH Compax3 SMB TBL/TBF, SLVD, ViX Servo, HiDrive, SPD, TWIN SME Aries, ViX Servo	MH Compax3 MB TBL/TBF, SLVD, ViX Servo, HiDrive, SPD, TWIN ME Aries, ViX Servo
Options	Cable, plug, terminal box Increased moment of inertia, holding brake	Cable, plug, terminal box, Moment of inertia, holding brake, passive cooling
Spezial features/ Usage	Used in highly-dynamic and high torque applications	Used in highly-power usage

Stepper motors

Parker Hannifin's stepper motors comply with NEMA standards 23 and 34, and are each available in three different stack lengths. These two-phase stepper motors are suitable for high-power applications and are used in combination with the ViX and XL stepper motor drives.

Stepper motor technical data (summary)

	SY
Holding torque [Nm]	0.45-5.4
Rotor inertia [kgmm²]	12.5-1200
Flange	56x56 / 86x86 / NEMA23/NEMA34 in 1-3 stacks / NEMA42 in 2-3 stacks
Stepper motor controllers	ViX Stepper / XL / XLi
Options	Cable / terminal box



Linear servo motor kits

Type	Ironless	Iron-cored
Continuous force [N]	24 ... 878	154 ... 2230
Peak force [N]	108 ... 3928	587 ... 7433
Cogging force	no	yes
Power density	low/medium	high
Attractive force	none	high
Heat dissipation	-	++
Applications	dynamic, precision, uniform motion	Applications with high forces and highly dynamic
Maximum speed	depending on the mechanical guidance system	



Ironless



Iron-cored

Torque motor kits

Typical characteristic features of a torque motor are low speed and high torque. Torque motors have a relatively high number of poles and are available with either solid or hollow shaft. The absence of a gearbox results in improved dynamic performance in rotary

applications. The torque motors ST and STK are used for rotary applications. As an alternative to convection cooling, forced air or water cooling is available.

STK/ST technical data (summary)

	STK	ST
Continuous torque [Nm]	14.6 ... 2708	14.6 ... 111
Peak torque [Nm]	43 ... 9258	43 ... 372
Design	Motor kit	Complete motors
Outer diameter [mm]	145 ... 795	147 / 190
Length [mm]	119 ... 357	212 ... 452.5



STK Motor (Kit)

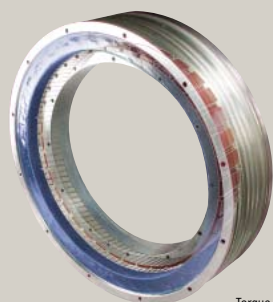

Torque motor (Kit)



ST Motor





■ Planetary gearboxes

A gearbox is necessary for many applications, and Parker Hannifin offers planetary gearboxes which are specifically adapted to electric drive technology. The gearboxes feature high efficiency, long service life and the ability to withstand high radial and axial forces at the shaft. Their noise emission is particularly low and all gearboxes are lifetime lubricated.

Depending on the applications, we can offer both economy gearboxes and precision planetary gearboxes with backlash less than 3 arc-minutes.

PTN:



Economy uniflange series

- Reduction ratio: 4:1, 8:1, 25:1
- Torque: 16Nm ...230Nm
- Flanges:
 - 60, 80, 115mm on the drive side
 - Uniflange on the motor side
- Input speed up to 4000min⁻¹
- Efficiency up to 96% (4:1; 8:1)
> 94% (25:1)



Precision

- Reduction ratio: 3:1 up to 100:1
- Torque: 50Nm up to 1100Nm
- Backlash:
 - 1 step < 4 arc-minutes
 - 2 step < 5 arc-minutes
 - available to < 1 arc-minutes
- Flanges: 60 ... 160mm
- Input speed up to 6000min⁻¹
- Efficiency up to 97%
- Low-noise: <60db

All gearboxes can be modified to suit customer requirements.





■ Handling actuators

All linear actuators offered by Parker Hannifin feature a modular and therefore flexible structure. They reflect Parker's long practical experience in the field of handling technology. In addition, we have developed special solutions for various applications, such as actuators suitable for clean-room applications as well as actuators for the food industry. The mechanical components can be combined to create multi-axis systems with the aid of a range of attachments and accessories. The user can choose between different versions including linear, vertical and telescopic actuators as well as electric cylinders. In addition, several different drive technologies are available including ballscrews, toothed belt drive, linear motor and a combination of toothed belt and toothed rack.



PowerRod PRA, PRC technical data

	PRA	PRC
Profile/cross-section [mm]	Ø25/68*54 Ø38/84*70	Ø25/68*54 Ø38/84*70
Drive Type	Linear motor	Linear motor
Maximum stroke [mm]	27.. 318	up to 1362
Maximum speed [m/s]	5.9	9.4
Maximum force [N]	312 ... 1860	312 ... 1860
Stainless/food option	✓	✓
Type	Linear motor Actuator	Linear motor Components
Feedback	Integrated length measuring system	

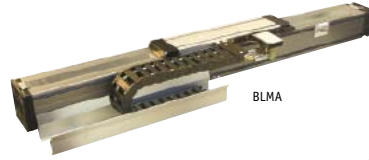
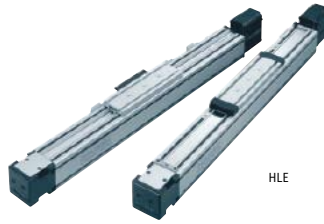

Technical data (summary)

	ET	HLE/HPLA	BLMA	HD
Profile/cross-section [CETOP]	32/50/80/100/125	80 ... 180 [mm]	120 [mm]	85x70 ... 185x95 [mm]
Drive Type	Screw	Toothed belt	Linear motor	Ball screw
Guide mechanism	Rollers/sliding bearing	Rollers	Rollers	-
Maximum stroke [mm]	50 ... 2400	5610 ... 9440	6329	100 ... 1600
Maximum speed [m/s]	1	5	7	1.48
Maximum force [N]	600 ... 44500	925 ... 3700	310/1693	90
Maximum load [kg]	-	150 ... 750	300	170 ... 780
Repeatability [mm]	± 0.07/± 0.01	± 0.2	± 0.01	± 0.008
Clean room option	-	Yes	-	-
Stainless/food option	Yes	Yes	-	-
Type	Electric cylinder	Toothed belt module	Linear motor module	Screw

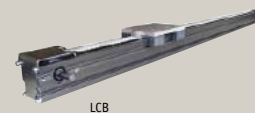

Technical data (summary)

	HZR	HTR	LCB
Profile/cross-section [mm]	50/80/100	50/80	40/60
Drive Type	Toothed belt	Toothed belt	Toothed belt
Guide mechanism	Rollers	Rollers	Sliding guide
Maximum load [kg]	30/50/150	24/49	480/760 (static)
Maximum speed [m/s]	5	5	8
Maximum stroke [mm]	1500/2000	3000/4000	2000/5500
Repeatability [mm]	± 0.2	± 0.2	± 0.2
Type	Vertical actuator	Vertical actuator (telescopic)	Toothed belt module

■ Precision actuators/tables

The precision tables and actuators are driven either by a ballscrew or by a linear motor. All mechanical components are optionally available for use in clean-room applications. The precision tables can be easily extended with corresponding accessories in order to build a complete X-Y or X-Y-Z system. All precision components are supplied with a performance certificate. Various options such as linear encoder systems, brakes, highly flexible cable sets and limit switches are available. The XR and LXR precision actuators achieve their high precision with

the aid of innovative ball bearing guides. The linear motor option helps both to increase the dynamic performance and to improve the precision. The XE "economy" version is compatible with the other products from the XR/LXR family.

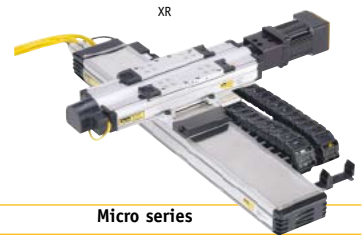

Ballscrew-driven tables

	404XE (Economy)	401 ... 412XR	Ultra series	Micro series
Stroke [mm]	25 ... 700	50 ... 2000	100 ... 500	50 ... 150
Drive Type	Ballscrew	Ballscrew	Ballscrew/Linear Motor	Ballscrew
Maximum load [kg]	630	50 ... 1470	1589 ... 2187	117 ... 652
Maximum speed [m/s]	0.3 ... 1.5	0.3 ... 1.5	1.5	0.012 ... 0.1
Repeatability [μm]	± 20 ... 30	± 1.9 ... 5.0	± 0.5	± 1.0

Linear motor driven tables

	404 ... 412LXR	Trilogy Ironless	Trilogy Ironcore
Stroke [mm]	50 ... 3000	100 ... 4200	100 ... 3600
Drive Type	Linear motor	Linear motor	Linear motor
Maximum load [mm]	45 ... 950	100 ... 450	27 ... 181
Maximum speed [m/s]	3.0	7	7
Repeatability [μm]	1 ... 5	1 ... 5	1 ... 5



Miniature tables: MX80 and LX80L

The precision tables are available with different drive types including standard and high-precision ballscrews, linear motors and micrometer screws.



MX80-Family

Technical data (summary)

	MX80M	MX80SP	MX80SS	MX80LP	MX80LS	LX80L
Profile/cross-section [mm]	80 x 25	80 x 35	80 x 35	80 x 25	80 x 25	80 x 45
Material	Aluminium	Aluminium	Aluminium	Steel	Aluminium	Aluminium
Drive Type	Micrometer	Ballscrew	Ballscrew	Linear motor	Linear motor	Linear motor
Maximum stroke [mm]	50	25 ... 150	25 ... 150	25 ... 150	25 ... 150	750
Maximum speed [m/s]	-	0.1	0.2	up to 2	up to 2	0.3
Maximum force [N]	-	123	44	12	12	10
Maximum load [kg]	20	8	8	8	8	10
Repeatability [µm]	-	± 1.5	± 5.0	± 0.4	± 0.8	± 1.5

Precision elevating table ZP200

ZP200 is a precision elevating table suitable for loads of up to 75kg. Like all precision products, the ZP200 is supplied with a test certificate and is optionally available for class 10 clean rooms.



ZP200

Technical data (summary)

	ZP200P	ZP200S
Profile/cross-section [mm]	200 x 60,4	200 x 60,4
Drive Type	Ballscrew	Ballscrew
Maximum stroke [mm]	25	25
Maximum speed [m/s]	0.44	0.44
Maximum load [kg]	15	75
Repeatability [µm]	± 3.0	± 5.0

Rotary tables

Technical data (summary)

	DD Rotary	200RT
Profile [mm]	100 ... 200	125 ... 300
Drive Type	Linear motor	Worm drive
Maximum speed [RPM]	300 ... 700	5 ... 25
Maximum torque [Nm]	0.65 ... 7.0	2.8 ... 21.5
Maximum load [kg]	75 ... 250	11 ... 90
Repeatability [arc/s]	± 4.1	20



DD Rotary

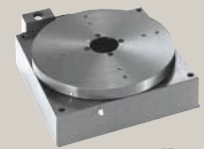

200RT

Europe

Parker Hannifin GmbH & Co. KG
Electromechanical Automation
 Robert-Bosch-Strasse 22
 D-77656 Offenburg, Germany
 Tel. +49 (0) 7 81/509-0
 Fax +49 (0) 7 81/509-98 176
 www.parker-eme.com
 sales.hauser@parker.com

Parker Hannifin S. p. A
Electromechanical Automation
 Via Gounod, 1
 I-20092 Cinisello Balsamo (MI), Italy
 Tel. +39 (0) 26 60/12459
 Fax +39 (0) 26 60/12808
 www.parker-eme.com
 sales.sbc@parker.com

Parker Hannifin plc
Electromechanical Automation
 Arena Business Centre
 Holy Rood Close, Poole, Dorset.
 BH17 7BA UK
 Tel. +44 (0)1202 606300
 Fax +44 (0)1202 606301
 www.parker-eme.com
 sales.digiplan@parker.com

Brazil

Parker Hannifin Industria e Comercio Ltda
Automation Division
 Av. Lucas Nogueira Garcez, 2181
 Esperança - Caixa Postal 148
 CEP 12325-900 - Jacareí, SP
 Tel. +55 12 3954 5100
 Fax +55 12 3954 5266
 www.parker.com/automation
 valeparaiba@parker.com

North America

Parker Hannifin Corporation
Electromechanical Automation
 5500 Business Park Drive
 Rohnert Park, CA 94928-7904, USA
 Tel. +1 707 584 7558
 Fax +1 707 584 3715
 www.parker.com/automation
 EMN_support@parker.com

Parker Hannifin Corporation
Electromechanical Automation
 50 West TechneCenter Drive
 Milford, Ohio 45150, USA
 Tel. +1 513 831 2340
 Fax +1 513 831 5042
 www.parker.com/automation
 moreinfo@ctcusa.com

Parker Hannifin Corporation
Electromechanical Automation
 27 Seaview Blvd
 Port Washington
 NY 11050
 Tel. (516) 484 5353
 Fax (516) 629 8000
 www.parker.com/automation

Parker Hannifin Corporation
Electromechanical Automation
 17101 Mill Forest Road.
 Webster, TX 77598
 Tel. (281) 226 7750
 Fax (281) 226 7760
 www.parker.com/automation

Parker Hannifin Corporation
Electromechanical Automation
 1140 Sandy Hill Road
 Irwin, PA 15642, USA
 Tel. +1 724 861 8200
 Fax +1 724 861 3330
 www.parker.com/automation
 ddlcat@parker.com

Parker Hannifin Corporation
Electromechanical Automation
 2101 North Broadway
 New Ulm
 MN 56073 USA
 Tel. 507 354 1616
 Fax 507 354 1611
 www.parker.com/automation

Mexico

Parker Hannifin de Mexico
Automation Division
 Eje 1 Norte #100
 Parque Industrial Toluca 2000
 Toluca, C.P. 50100
 Tel. +52 722 275 4200
 Fax +52 722 279 9308
 www.parker.com/automation

China

Parker Hannifin Fluid Power
Systems & Components Co. Ltd.
 280 Yun Quao Road, Jin Qiao
 Export Processing Zone
 Shanghai 201206, PR China
 Tel. +86 21 5031 2525
 Fax +86 21 585 48 975
 www.parker.com/automation

Parker Hannifin Hong Kong Ltd.
Automation
 8/F, Kin Yip Plaza
 9 Cheung Yee Street, Cheung Sha Wan
 Kowloon, Hong Kong
 Tel. +852 2260 8240
 Fax +852 2425 6896
 www.parker.com/automation

Singapore

Parker Hannifin Singapore Pte. Ltd.
Automation
 11, Fourth Chin Bee Road
 Singapore 619702
 Republic of Singapore
 Tel. +65 6887 6300
 Fax +65 6265 5125/ 6261 4929
 www.parker.com/automation
 parkersg@parker.com

anything **Parker**
Possible.™